



MXB7846 Evaluation Kit/Evaluation System

General Description

The MXB7846 evaluation system (EV system) is a complete touch-screen controller data-acquisition system consisting of a MXB7846 evaluation kit (EV kit) and a Maxim 68HC16MODULE-DIP microcontroller (μ C) module. The MXB7846 is an industry-standard, 4-wire touch-screen controller. Windows® 98/2000 software provides a handy user interface to exercise the features of the MXB7846.

Order the complete EV system (MXB7846EVC16) for comprehensive evaluation of the MXB7846 using a personal computer. Order the EV kit (MXB7846EVKIT) if the 68HC16MODULE module has already been purchased with a previous Maxim EV system, or for custom use in other μ C-based systems.

To evaluate the MXB7843, request a free sample of the MXB7843EEE.

Windows is a registered trademark of Microsoft Corp.

Features

- ◆ Proven PC Board Layout
- ◆ Complete Evaluation System
- ◆ Convenient Test Points Provided On Board
- ◆ Data-Logging Software
- ◆ Fully Assembled and Tested

Ordering Information

PART	TEMP RANGE	INTERFACE TYPE
MXB7846EVKIT	0°C to +70°C	User supplied
MXB7846EVC16	0°C to +70°C	Windows software

Component List

DESIGNATION	QTY	DESCRIPTION
C1	1	0.01 μ F ceramic capacitor
C2, C3, C4, C12	4	0.1 μ F ceramic capacitors
C5	1	10 μ F \pm 20%, 10V (6.3V min) X7R ceramic capacitor Taiyo Yuden LMK325BJ106MN
C6-C11	0	Open
C13	1	4.7 μ F \pm 20%, 10V X7R ceramic capacitor Taiyo Yuden LMK316BJ475ML
JU1	1	3-pin header
JU2	1	2-pin header

DESIGNATION	QTY	DESCRIPTION
J1	1	2 \times 20 right-angle socket, SamTec SSW-120-02-S-D-RA
R1	1	100k Ω \pm 5% resistor
R2-R7	0	Open
TP1, TP2	2	8-pin headers
U1	1	MXB7846EEE
U2	1	MAX6192ACSA
U3, U4	2	MAX1840EUB
U5	1	MAX1615EUK-T
None	1	3 1/2in software disk
None	1	MXB7846 data sheet
None	1	MXB7846 EV kit data sheet
None	1	68HC16MODULE manual

Evaluates: MXB7843/MXB7846

MXB7846 Evaluation Kit/Evaluation System

MXB7846 Stand-Alone EV Kit

The MXB7846 EV kit provides a proven PC board layout to facilitate evaluation of the MXB7846. It must be interfaced to appropriate timing signals for proper operation. Connect +3V to V_{DD}, and connect ground return to GND (Figure 7). Refer to the MXB7846 data sheet for timing requirements.

If used with a +5V system, the on-board MAX1615 linear regulator and MAX1840 level translators can be used. Note that the MAX1840 level translators cannot withstand a supply voltage exceeding +5.5V.

MXB7846 EV System

The MXB7846EVC16 EV system operates from a user-supplied +7VDC to +20VDC power supply. Windows 98/2000 software running on an IBM PC interfaces to the EV system board through the computer's serial communications port. See the *Quick Start* section for setup and operating instructions.

Quick Start

Recommended Equipment

Before you begin, the following equipment is needed:

- Maxim MXB7846EVKIT and 68HC16MODULE interface board
- A small DC power supply, such as a +12VDC 0.25A plug-in transformer, or a 9V battery
- A computer running Windows 98/2000
- A spare serial communications port, preferably a 9-pin plug
- A serial cable to connect the computer's serial port to the 68HC16MODULE
- Resistive 4-wire touch-screen panel

Procedure

Words in boldface indicate user-selectable features in the software.

- 1) Ensure that the jumper settings are in the default position (see Table 1).
- 2) Carefully connect the boards by aligning the 40-pin header of the MXB7846 EV kit with the 40-pin connector of the 68HC16MODULE-DIP module. Gently press them together. The two boards should be flush against one another.
- 3) With the power off, connect a +7VDC to +20VDC power supply to the μ C module at the terminal block located next to the on/off switch, along the top edge of the μ C module. Observe the polarity marked on the board.
- 4) Connect a cable from the computer's serial port to the μ C module. If using a 9-pin serial port, use a straight-through, 9-pin female-to-male cable. If the only available serial port uses a 25-pin connector, a standard 25-pin to 9-pin adapter is required. The EV kit software checks the modem status lines (CTS, DSR, DCD) to confirm that the correct port has been selected.
- 5) Connect your touch-screen panel to the X+, X-, Y+, and Y- terminals of the EV kit.
- 6) Install the EV system software on your computer by running the INSTALL.EXE program on the floppy disk. The program files are copied and icons are created for them in the Windows Start Menu.
- 7) Turn on the power supply.
- 8) Start the program by opening its icon in the Start Menu.
- 9) The program prompts you to connect the μ C module and turn its power on. Slide SW1 to the ON position. Select the correct serial port, and click **OK**. The program automatically loads code into the module.
- 10) Once the module is loaded, the main window appears (see Figure 1). Verify the connections by making a large circle on the touch-screen surface.
- 11) After verifying that the X and Y axes are wired correctly, bring up the **Calibration** tab, click **Measure Touchscreen Idle Threshold**, and then click **Erase**. The right side of the main window should now track the touch screen.

Detailed Description of Software

The evaluation software tracks the touch screen in the right half of the main window. The **Measurement** tab tracks touch-screen input, device temperature, and auxiliary inputs. The **Calibration** tab provides simple, linear adjustment of the software's voltage and temperature displays. The **Control** tab determines the control word used for each input channel. The **Low Level** tab controls the 68HC16 module's QSPI interface parameters. The **Output Codes** tab displays the raw, unprocessed output code value of each input channel, in binary, unsigned decimal, and as a percent of full scale.

Reference Voltage

The evaluation software assumes a +2.5V reference voltage, unless otherwise specified. To override this value, select the **Calibration** tab, and type the new reference voltage into the field named **Reference Voltage**.

MXB7846 Evaluation Kit/Evaluation System

Evaluates: MXB7843/MXB7846

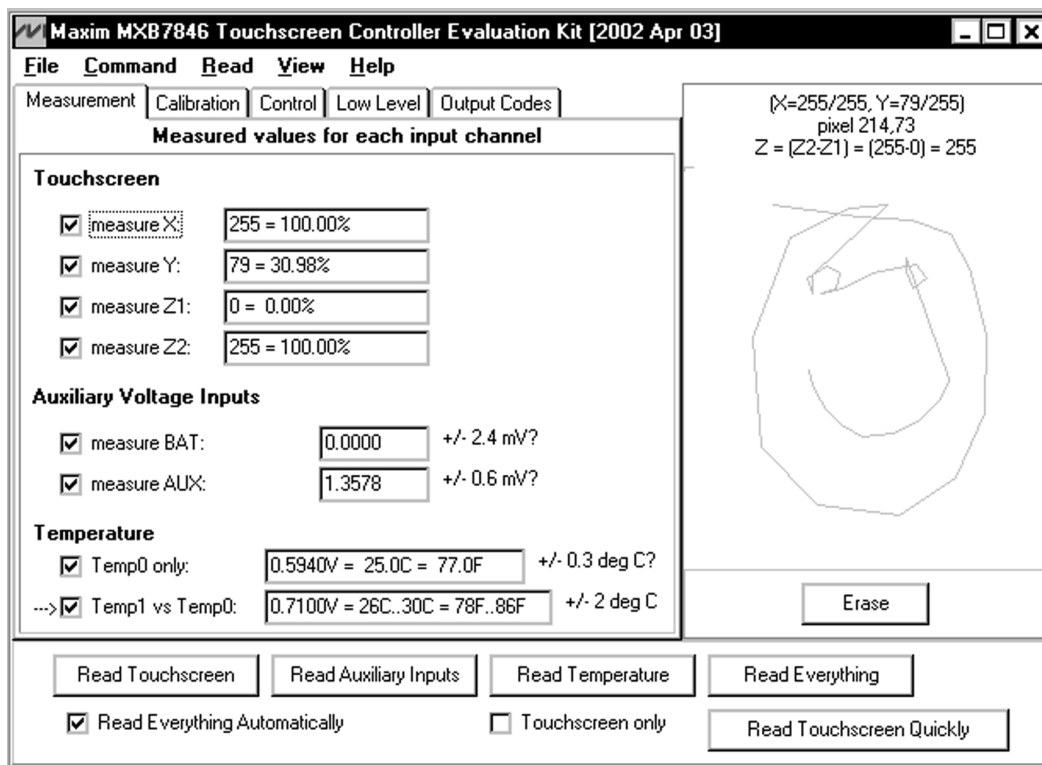

NOTE: THE EVALUATION SOFTWARE TRACKS THE TOUCH SCREEN IN THE RIGHT HALF OF THE MAIN WINDOW. THE **MEASUREMENT** TAB TRACKS TOUCH-SCREEN INPUT, DEVICE TEMPERATURE, AND AUXILIARY INPUTS.

Figure 1. MXB7846 Touch-Screen Controller EV Kit—Measurement Tab

Increasing Acquisition Time

A high-impedance source can require a longer acquisition time for accurate measurement. From the evaluation software's **Low Level** tab, set **QSPI clock** to a sufficiently slow serial clock speed. The minimum clock rate the 68HC16 module supports is 33kHz, which corresponds to an acquisition time of 91µs.

Detailed Description of Hardware

The MXB7846 (U1) is an industry-standard, 4-wire touch-screen controller. Resistors R2–R7 and capacitors C6–C11 are reserved for optional user-supplied, single-pole, low-pass, anti-aliasing filters. C3 bypasses the ADC's voltage reference. When plugged into the

68HC16MODULE, the MAX1615 (U5) provides +3V power to the MXB7846, and the MAX1840 level shifters (U3 and U4) translate the 68HC16MODULE's +5V logic signals to +3V logic. See Figure 7, *MXB7846 EV Kit Schematic*, and refer to the MXB7846 data sheet.

Touch-Screen Equivalent Circuit

For prototyping purposes, a 4-wire resistive touch screen can be simulated using two variable resistors connected by a resistor and a switch. Variable resistor X, connected between X+ and X-, should be approximately 100Ω to 500Ω. Variable resistor Y, connected between Y+ and Y-, should be approximately 100Ω to 500Ω. Connect the center wipers of the two variable resistors using a fixed resistor of approximately 300Ω, simulating the touch resistance (Figure 6).

MXB7846 Evaluation Kit/Evaluation System

Evaluates: MXB7843/MXB7846

Maxim MXB7846 Touchscreen Controller Evaluation Kit [2002 Apr 03]

File Command Read View Help

Measurement Calibration Control Low Level Output Codes

Calibration data for temperature and voltage measurement

Analog to Digital Converter Reference Voltage: 2.5000

Touchscreen Reset Touchscreen Idle Threshold

(Do not touch the touchscreen while resetting idle threshold.)

Auxiliary Voltage Inputs

	Full Scale [V]	Offset [V]
BAT voltage input range (6V MAX)	10.0000	0.000
AUX voltage input range	2.5000	0.000

Temperature

Test temperature deg C: 25 Measure TEMP0 Voltage

TEMP0 voltage at test temperature: 0.600

degrees Kelvin per delta mV (TEMP1 vs TEMP0): 2.60

(X=255/255, Y=62/255)
pixel 214,57
Z = [Z2-Z1] = (255-2) = 253

Erase

Read Touchscreen Read Auxiliary Inputs Read Temperature Read Everything

Read Everything Automatically Touchscreen only Read Touchscreen Quickly

NOTE: THE CALIBRATION TAB PROVIDES SIMPLE, LINEAR ADJUSTMENT OF THE SOFTWARE'S VOLTAGE AND TEMPERATURE DISPLAYS.

Figure 2. MXB7846 Touch-Screen Controller EV Kit—Calibration Tab

MXB7846 Evaluation Kit/Evaluation System

Evaluates: MXB7843/MXB7846

Maxim MXB7846 Touchscreen Controller Evaluation Kit [2002 Apr 03]

File Command Read View Help

Measurement Calibration Control Low Level Output Codes

Control Byte Values for each input channel

	MODE	SER/DFR	PD MODE
1000 (Temp0)	0 (12-bit)	1 (s.e.)	11 (ref on, adc on)
1001 (Y)	1 (8-bit)	0 (diff.)	01 (ref off, adc on)
1010 (BAT)	0 (12-bit)	1 (s.e.)	11 (ref on, adc on)
1011 (Z1: X+)	1 (8-bit)	0 (diff.)	01 (ref off, adc on)
1100 (Z2: Y-)	1 (8-bit)	0 (diff.)	01 (ref off, adc on)
1101 (X)	1 (8-bit)	0 (diff.)	01 (ref off, adc on)
1110 (AUX)	0 (12-bit)	1 (s.e.)	11 (ref on, adc on)
---> 1111 (Temp1)	0 (12-bit)	1 (s.e.)	11 (ref on, adc on)

(X=255/255, Y=76/255)
pixel 214,70
Z = [Z2-Z1] = (255-1) = 254

Erase

Read Touchscreen Read Auxiliary Inputs Read Temperature Read Everything

Read Everything Automatically Touchscreen only Read Touchscreen Quickly

NOTE: THE CONTROL TAB DETERMINES THE CONTROL WORD USED FOR EACH INPUT CHANNEL.

Figure 3. MXB7846 Touch-Screen Controller EV Kit—Control Tab

MXB7846 Evaluation Kit/Evaluation System

Evaluates: MXB7843/MXB7846

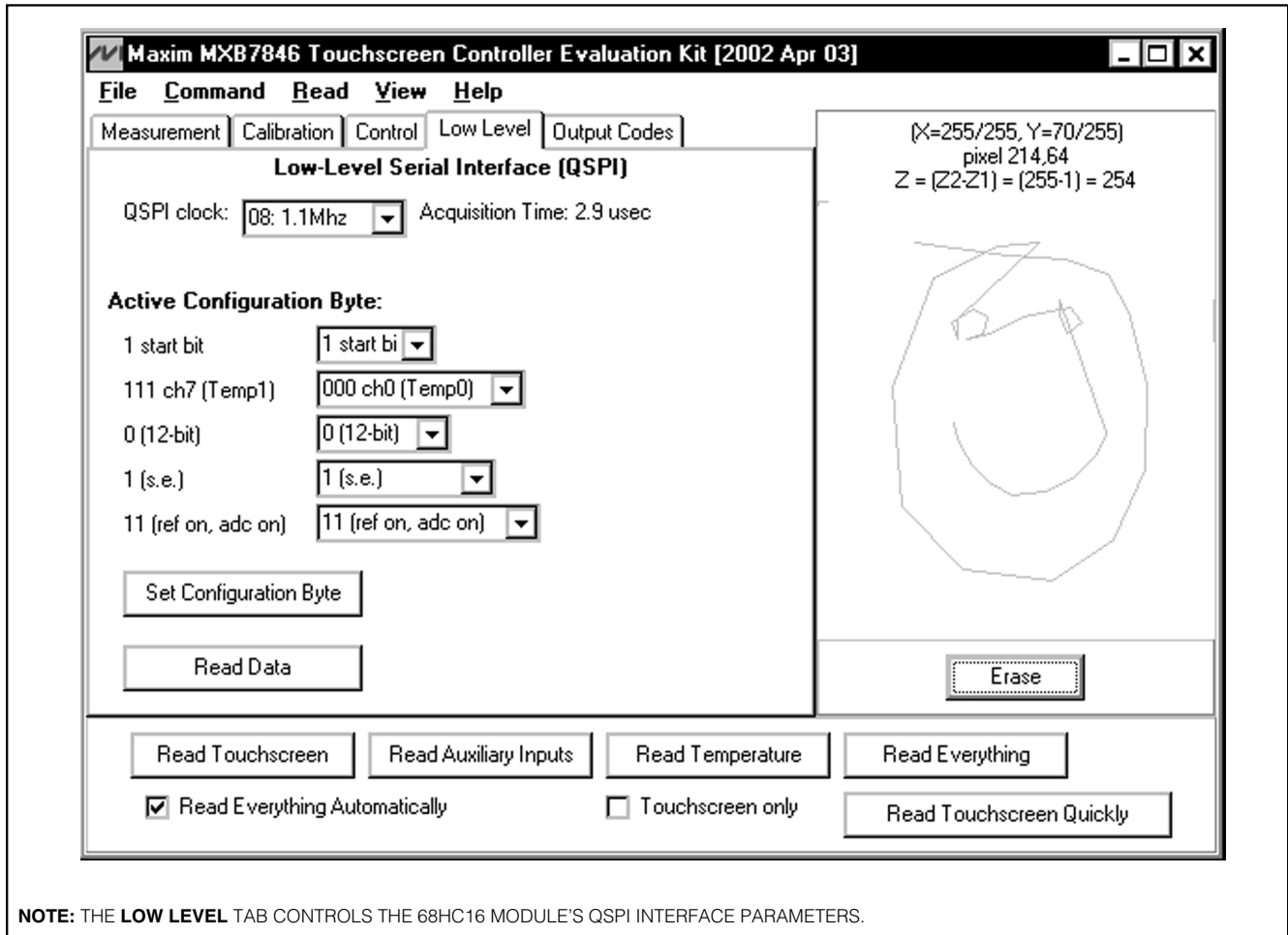

NOTE: THE **LOW LEVEL** TAB CONTROLS THE 68HC16 MODULE'S QSPI INTERFACE PARAMETERS.

Figure 4. MXB7846 Touch-Screen Controller EV Kit—Low-Level Tab

MXB7846 Evaluation Kit/Evaluation System

Evaluates: MXB7843/MXB7846

The screenshot shows the 'Maxim MXB7846 Touchscreen Controller Evaluation Kit [2002 Apr 03]' window. The 'Output Codes' tab is selected, displaying a table of output code values for each input channel. The table lists channels such as Temp0, Y, BAT, Z1: X+, Z2: Y-, X, AUX, and Temp1, along with their binary values, decimal values, and percentages of full scale. A touch event is shown on the right with coordinates (X=255/255, Y=58/255) and a Z value of 252. The interface includes buttons for 'Read Touchscreen', 'Read Auxiliary Inputs', 'Read Temperature', 'Read Everything', 'Read Touchscreen Quickly', and 'Erase', along with checkboxes for 'Read Everything Automatically' and 'Touchscreen only'.

Channel	Binary Value	Decimal Value	Percentage
1000 (Temp0)	0011 1101 0111	983	24.00%
1001 (Y)	0000 0011 1010	58	22.75%
1010 (BAT)	0000 0000 0010	2	0.05%
1011 (Z1: X+)	0000 0000 0011	3	1.18%
1100 (Z2: Y-)	0000 1111 1111	255	100.00%
1101 (X)	0000 1111 1111	255	100.00%
1110 (AUX)	0100 1101 1111	1247	30.45%
1111 (Temp1)	0100 1001 0110	1174	28.67%

Touch coordinates: (X=255/255, Y=58/255)
 pixel 214,53
 Z = (Z2-Z1) = (255-3) = 252

Buttons: Read Touchscreen, Read Auxiliary Inputs, Read Temperature, Read Everything, Read Touchscreen Quickly, Erase

Checkboxes: Read Everything Automatically, Touchscreen only

NOTE: THE **OUTPUT CODES** TAB DISPLAYS THE RAW, UNPROCESSED OUTPUT CODE VALUE OF EACH INPUT CHANNEL, IN BINARY, UNSIGNED DECIMAL, AND AS A PERCENT OF FULL SCALE.

Figure 5. MXB7846 Touch-Screen Controller EV Kit—Output Codes

MXB7846 Evaluation Kit/Evaluation System

Table 1. Jumper Functions

JUMPER	POSITION	FUNCTION
JU1	1-2	REF = V _{DD}
JU1	Open	REF = internal reference (MXB7846 only)
JU1	2-3*	REF = U2, MAX6192
JU2	Closed*	$\overline{\text{IRQ}}$ connects to μC GPIO pin
JU2	Open	$\overline{\text{IRQ}}$ not connected to μC

*Default configuration

Evaluating the MXB7843

The MXB7843 behaves like the MXB7846 with no temperature measurement, no internal reference, and an additional AUX input instead of BAT.

Troubleshooting

Problem: No output measurement. System seems to report zero voltage, or fails to make a measurement.

Check +5V and +3V supply voltages. Check the +2.5V reference voltage using a digital voltmeter. Use an oscilloscope to verify that the $\overline{\text{CS}}$ signal is being strobed.

Problem: Measurements are erratic, unstable; poor accuracy.

Check the reference voltage using a digital voltmeter. Use an oscilloscope to check for noise. When probing for noise, keep the oscilloscope ground return lead as short as possible, preferably less than 1/2in (10mm).

Problem: Trapezoidal distortion on touch screen.

Insufficient acquisition time can cause position-sensitive errors in touch-screen position measurement. Increase the acquisition time by reducing the clock rate. On the software's **Low-Level** tab, select a slower **QSPI Clock** setting.

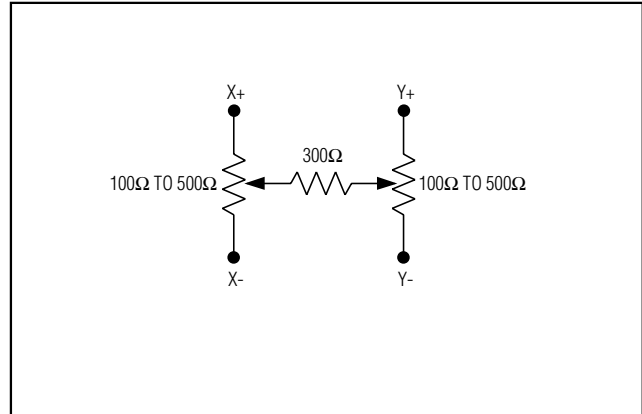

Figure 6. Touch-Screen Equivalent Circuit

MXB7846 Evaluation Kit/Evaluation System

Evaluates: MXB7843/MXB7846

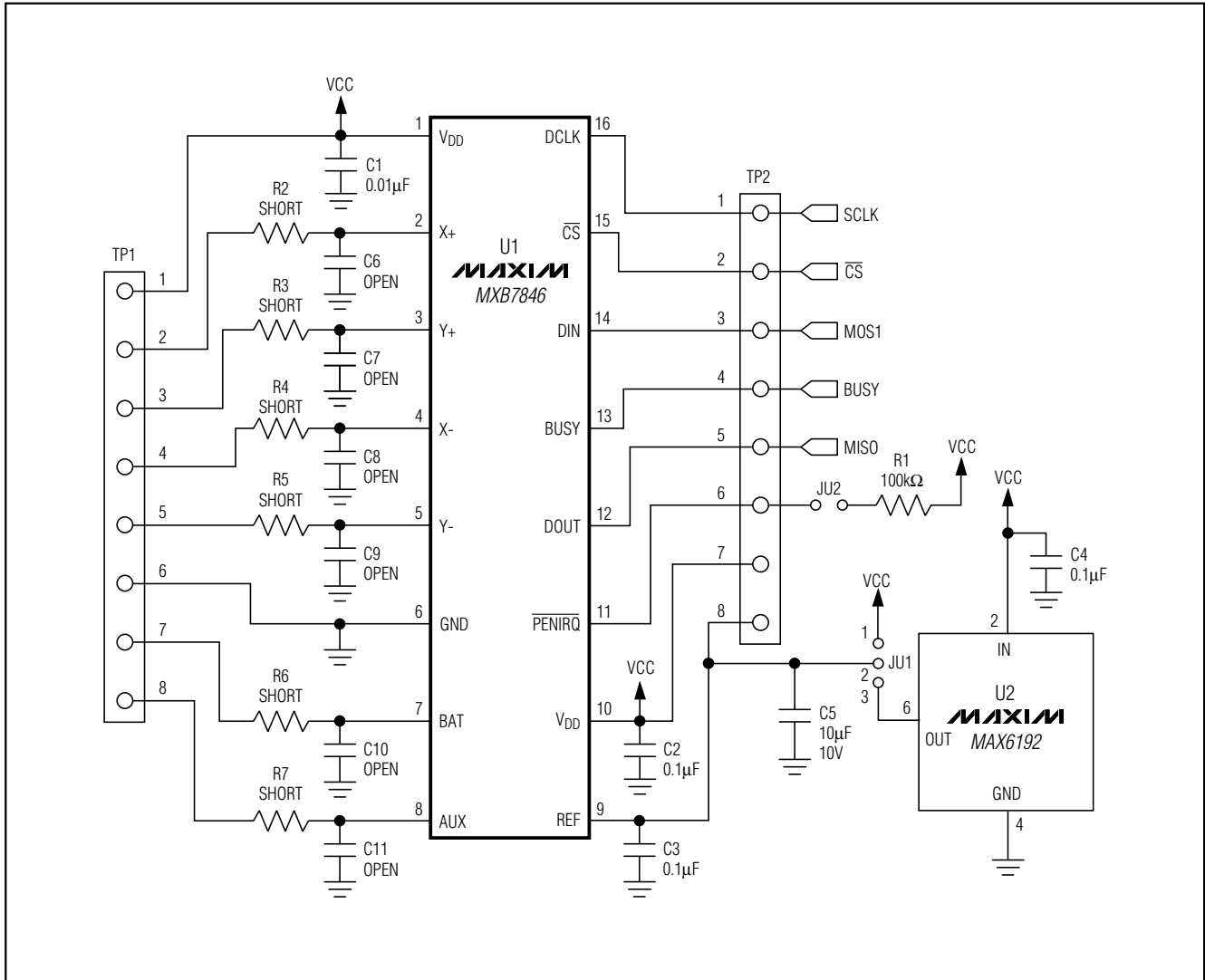

Figure 7. MXB7846 EV Kit Schematic (Sheet 1 of 2)

MXB7846 Evaluation Kit/Evaluation System

Evaluates: MXB7843/MXB7846

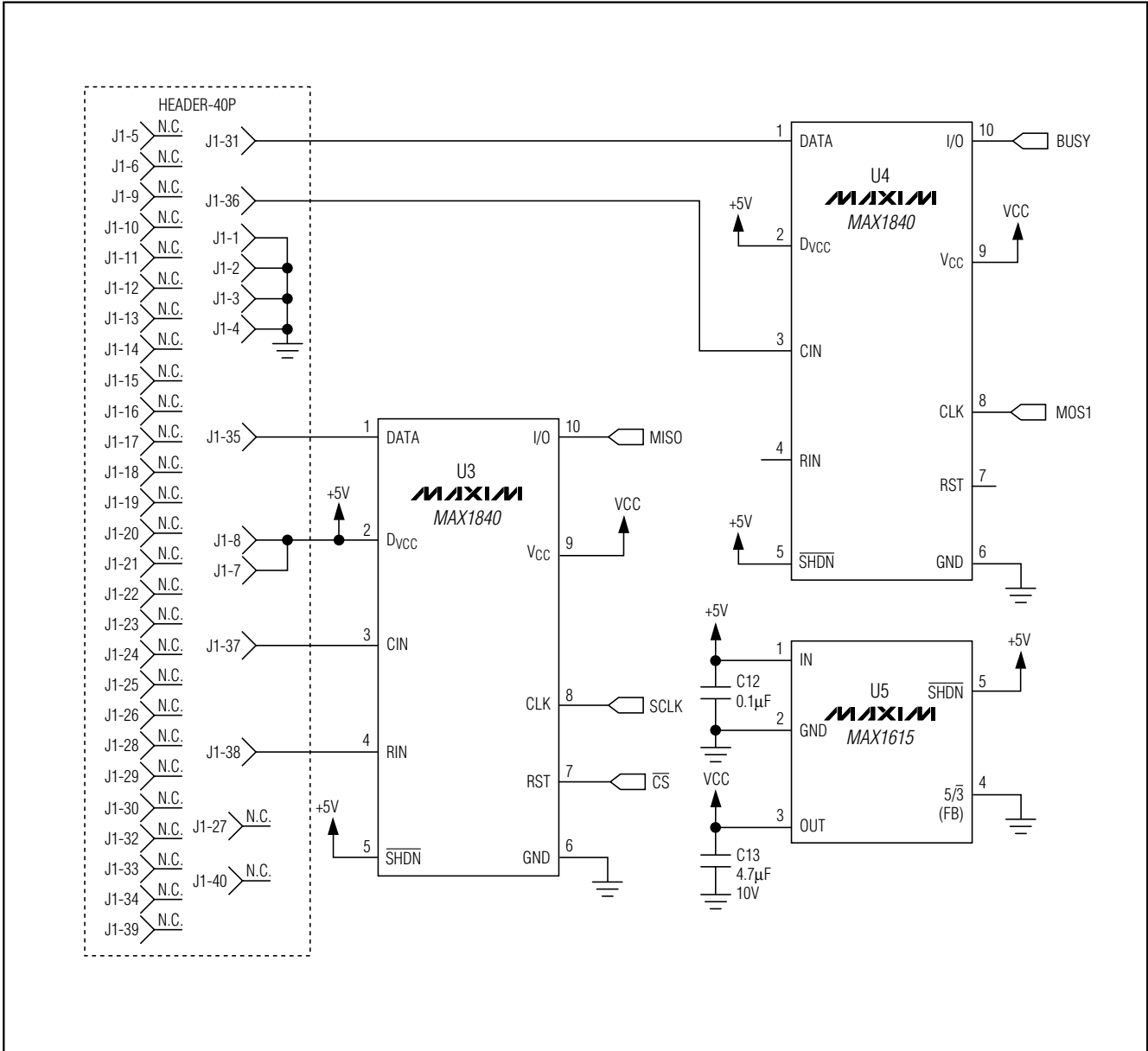

Figure 7. MXB7846 EV Kit Schematic (Sheet 2 of 2)

MXB7846 Evaluation Kit/Evaluation System

Evaluates: MXB7843/MXB7846

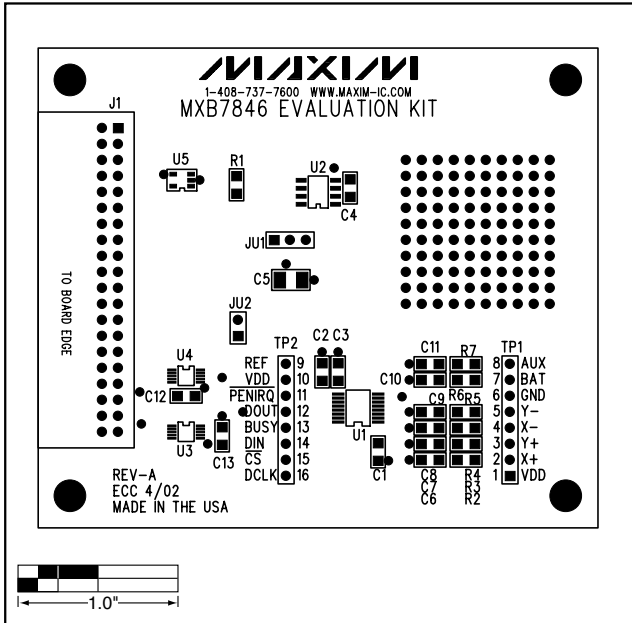

Figure 8. MXB7846 EV Kit Component Placement Guide—Component Side

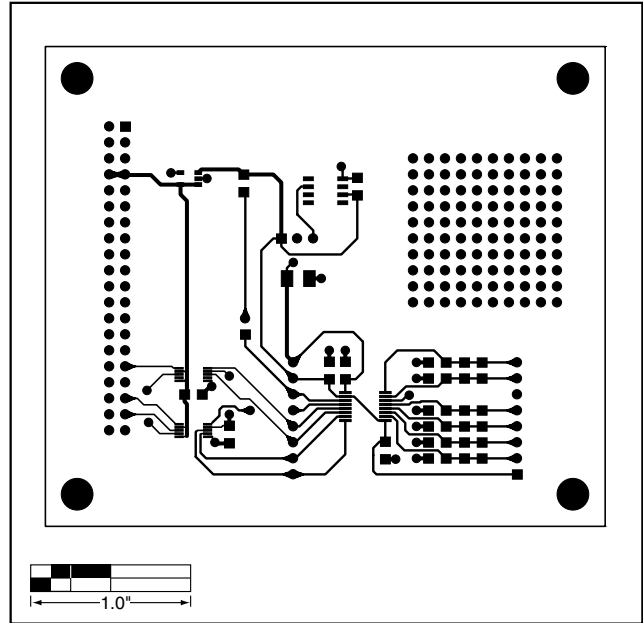

Figure 9. MXB7846 EV Kit PC Board Layout—Component Side

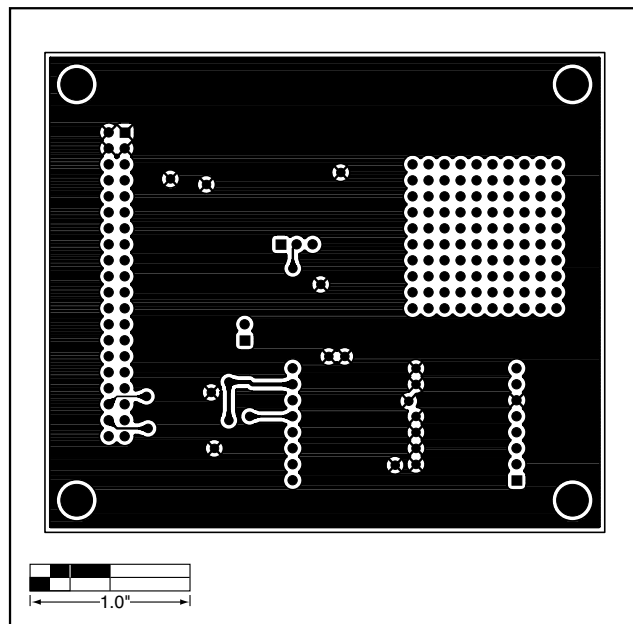

Figure 10. MXB7846 EV Kit PC Board Layout—Solder Side

Maxim cannot assume responsibility for use of any circuitry other than circuitry entirely embodied in a Maxim product. No circuit patent licenses are implied. Maxim reserves the right to change the circuitry and specifications without notice at any time.

Maxim Integrated Products, 120 San Gabriel Drive, Sunnyvale, CA 94086 408-737-7600 _____ 11